



Игорь ЛЕВИТ

Арт-директор «Штольцман и Кац»

Упаковка.

Тенденции и перспективы

Packaging. Trends and Outlook

**Штольцман и Кац**<sup>™</sup>

BRAND BUILDING AGENCY

Типология упаковки Packaging Types	3
Технологии печати Printing Technologies	11
Умная упаковка Smart Packaging	15
Креативная упаковка Creative Packaging	27
Упрощение Simplification	39

# Типология упаковки

Packaging types



По назначению

Purpose \ Function of Packaging

Потребительская

Consumer packaging (Primary)

Групповая

Group Packaging (Secondary)

Транспортная

Transport \ Distribution packaging (Tertiary)

# Потребительская упаковка

Consumer package (Primary)



# Групповая упаковка

## Group Packaging (Secondary)



# Транспортная упаковка

Transport \ Distribution packaging (Tertiary)





По составу

Packaging Components

Тара

Containers

Вспомогательные  
упаковочные средства

Auxiliary Packaging Components \ Pieces



# Тара

Containers



# Коробки

Boxes

# Ёмкости

Bottles, Jars



# Тубы

Tubes



# Гибкая упаковка

Flexible Packaging



# Вспомогательные упаковочные средства

Auxiliary Packaging Components \ Pieces

## Укупорочные изделия

Closures



## Этикетки

Labels



## Обёртка

Wrappers

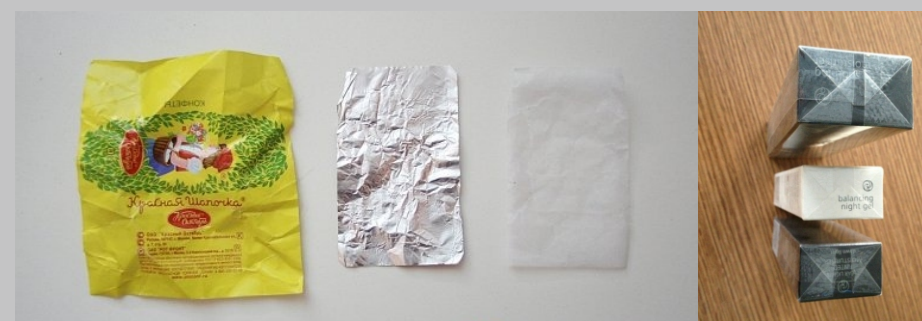

Технологии печати

Printing Technologies

# Компьютер — печатная форма

CtP (Computer-to-Plate) Technology



CtP Printer (Offset)



Laser Engraver (Flexography)

# Сервопривод ротационной печати

Servo-driven Printing

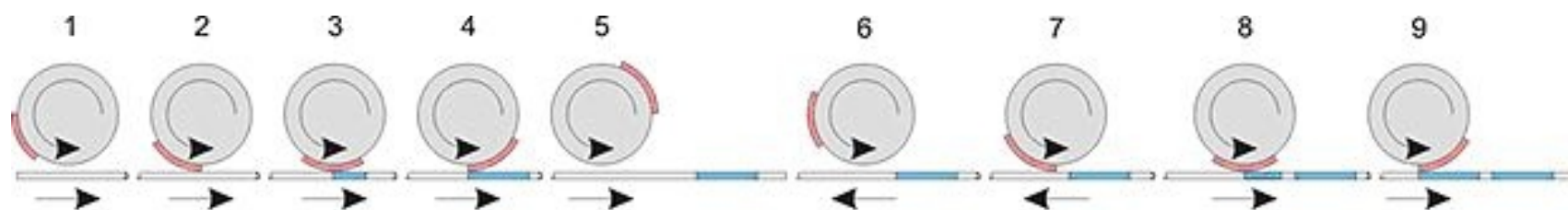
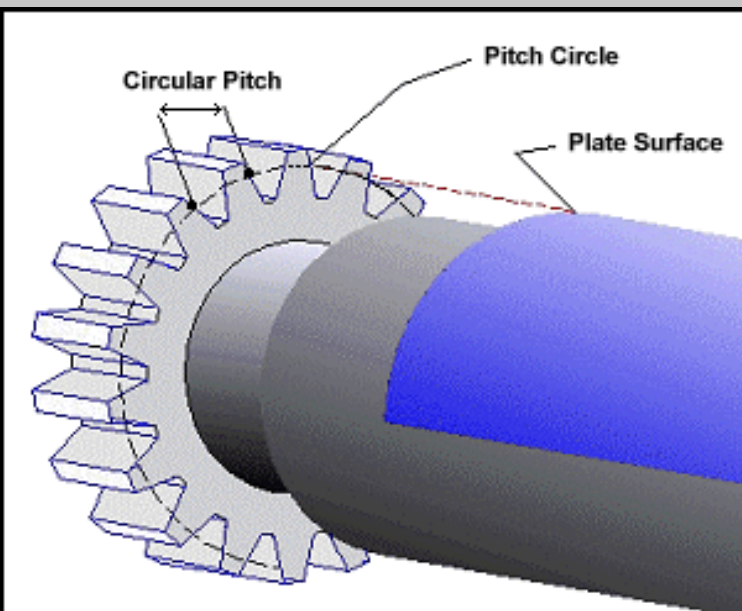

Условные обозначения



Материал  
Оттиск



Формный (офсетный) цилиндр



Печатная форма (офсетная резина)

# Лазерная высечка

Laser Cutting

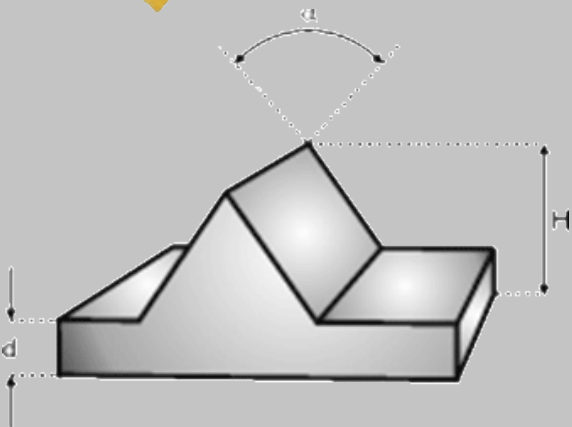
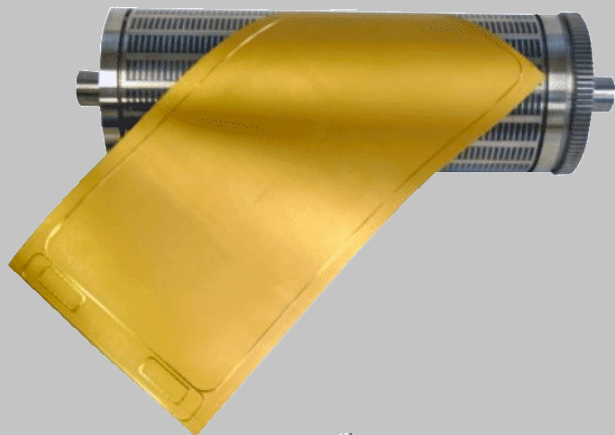

# Умная упаковка

Smart Packaging

(Active Packaging / Intelligent Packaging)



Функции «умной упаковки»

Purpose \ Function of Smart Packaging

Контроль данных

Data Control

Контроль качества

Quality Control

Помощь потребителю

Consumer Support



# Контроль данных о товаре

Product Data Control

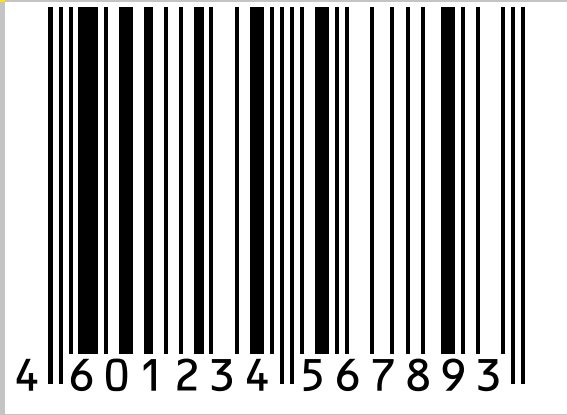

EAN-13



EAN-8

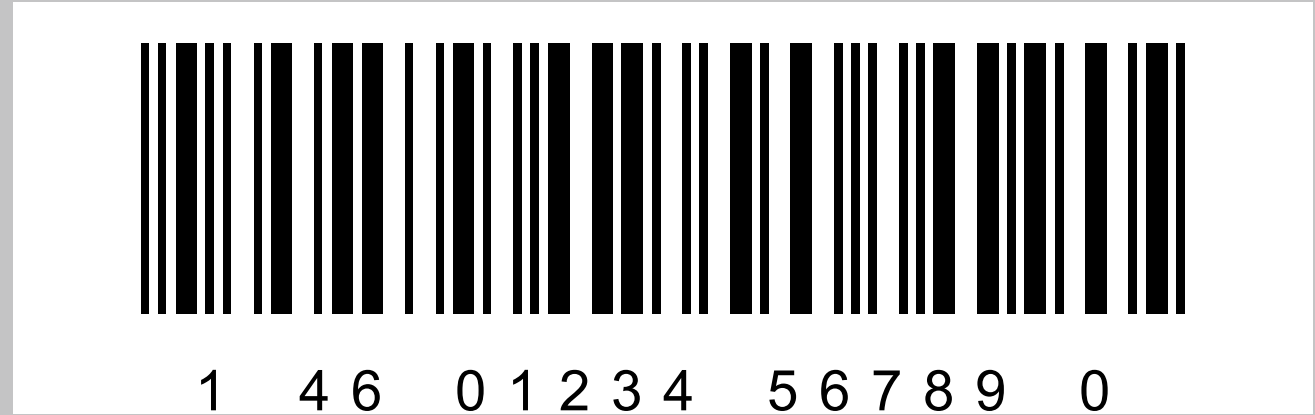

ITF-14



PDF417



Data Matrix



Aztec Code



QR

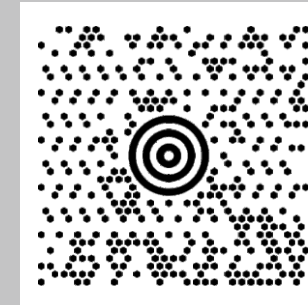

MaxiCode

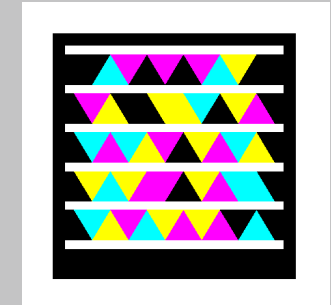

Microsoft Tag

# Контроль данных о товаре

Product Data Control

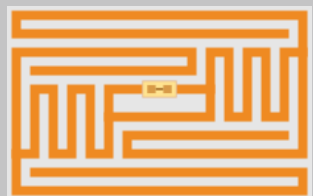
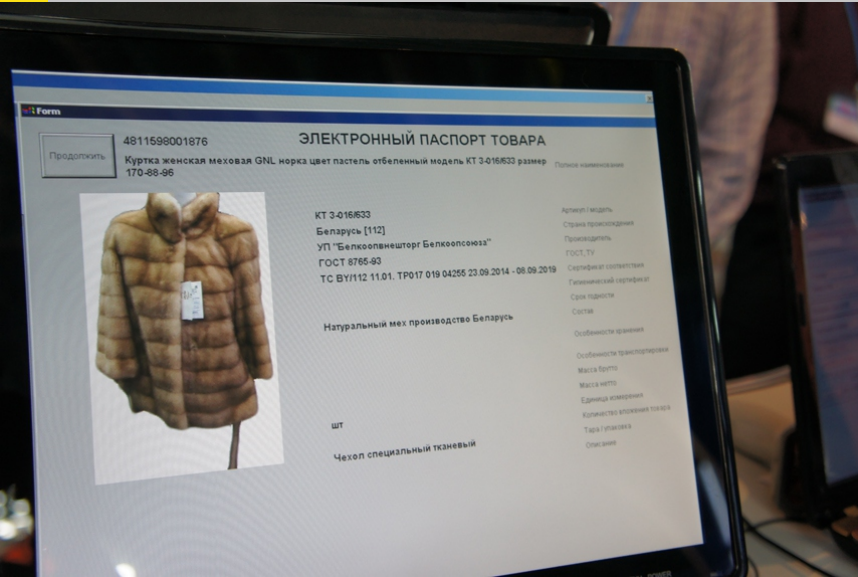

## RFID-метки

Radio Frequency Identification

# Контроль подлинности

Authenticity Validation



# Контроль подлинности

Authenticity Validation

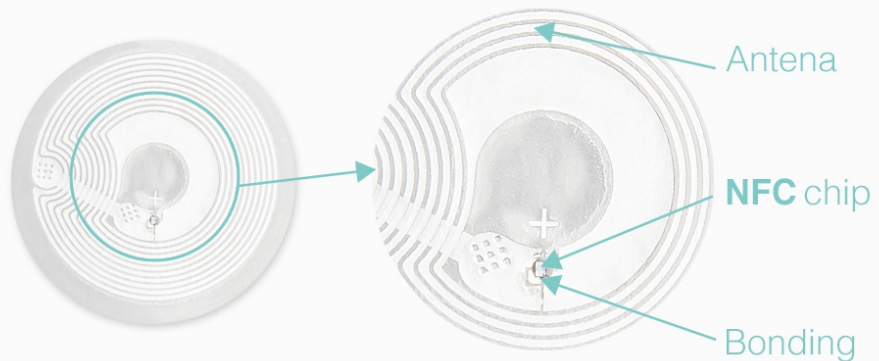
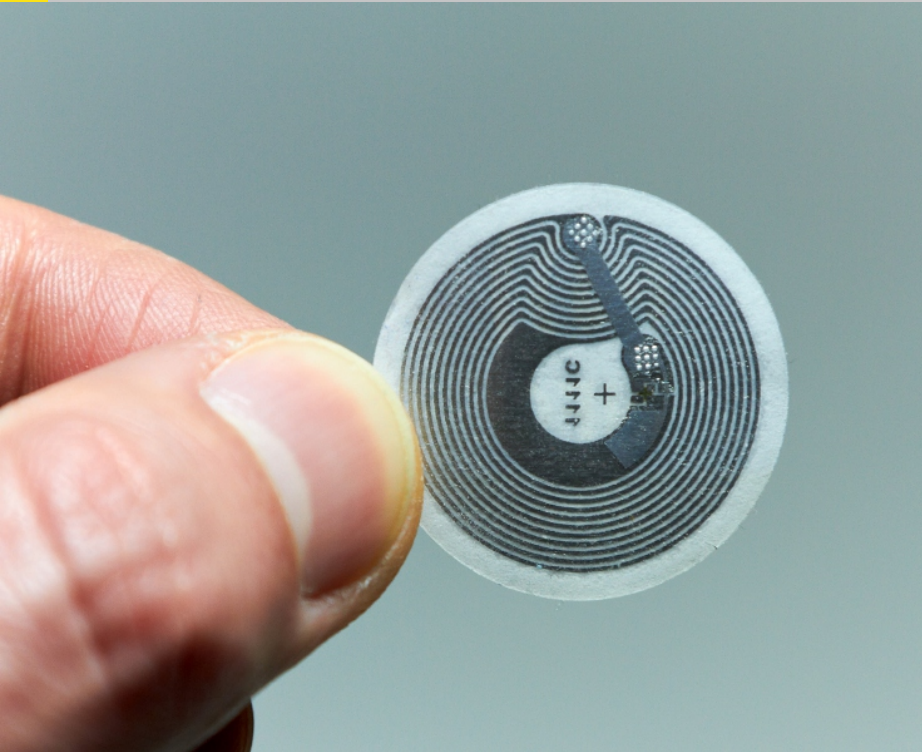

Current Design

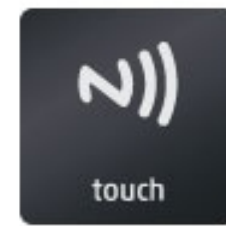

New Design



# Контроль свежести

Freshness Control



# Контроль свежести

Freshness Control



# Контроль температуры

# Temperature Control



# Контроль среды

# Environment Control



Oxygen Absorber



Desiccant



# Самонагревающаяся упаковка

Self-heating Packaging

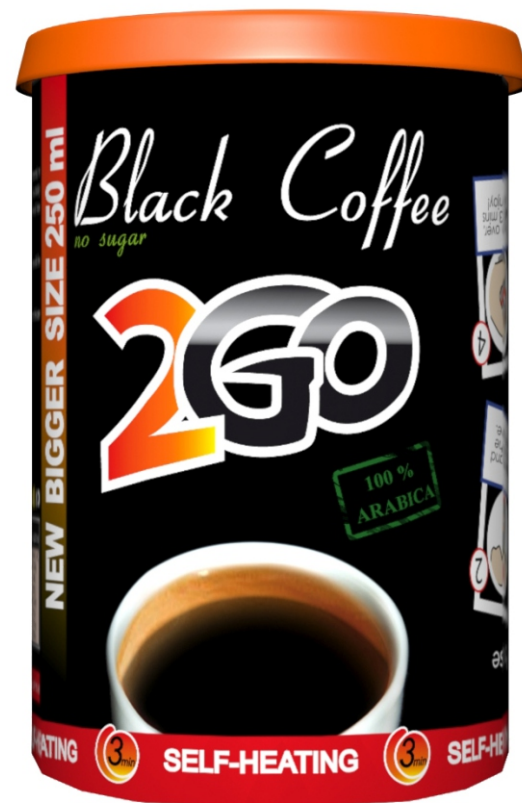

# Самоохлаждающаяся упаковка

Self-cooling Packaging

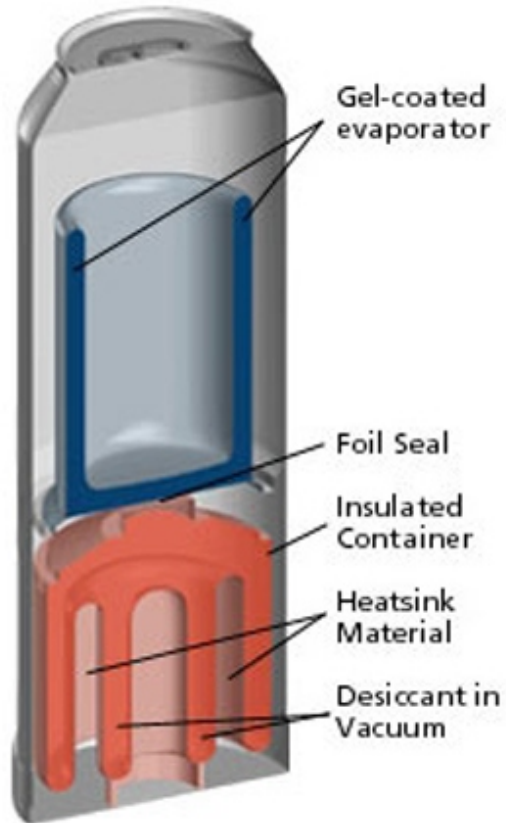

Креативная упаковка

Creative Packaging



Способы индивидуализации

Ways to Individualize

Особенности продукта

Product Features

Конструкция упаковки

Packaging Structure

Воздействие на органы чувств

Sensory Effects

# Образность продукта

Product Figurativeness



# Образность продукта

Product Figurativeness



# Образность продукта

Product Figurativeness



# Образность продукта

## Product Figurativeness





# Конструкция/образ

## Packaging Structure / Image



# Конструкция

## Packaging Structure



# Мультисенсорная упаковка

Multi-sensory Packaging



Запах Scent

# Мультисенсорная упаковка

Multi-sensory Packaging



Magnetic cap sound  
Gentle Scent of Lavender

Звук, запах  
Sound, Scent

Штольцман и Кац  
BRAND BUILDING AGENCY



# Мультисенсорная упаковка

Multi-sensory Packaging



Зрение, тактильные ощущения

Vision, Tactile Sense

# Мультисенсорная упаковка

Multi-sensory Packaging



Зрение, тактильные ощущения

Vision, Tactile Sense



Упрощение

Simplification

# Отказ от лишнего

Denial of Unnecessary



ORIGINAL  
UNVERPACKT  
Der neue Supermarkt

UNVERPACKT  
FÜR ALLE

Jetzt Realität werden lassen auf:  
[www.startnext.de/original-unverpackt](http://www.startnext.de/original-unverpackt)

THE KISS PRINCIPLE

**KEEP  
IT  
SIMPLE,  
STUPID**



**ECO  
FRIENDLY  
PACKAGING**

REDUCE, REUSE, RECYCLE



# Без упаковки

Without Packaging



# Упрощённая упаковка

Simplified Packaging

KEEP IT  
SIMPLE  
STUPID



# Экологичная упаковка

Green Packaging



**ECO  
FRIENDLY  
PACKAGING**  
REDUCE, REUSE, RECYCLE





# ВЫВОДЫ

Conclusion



# Встречное движение

Opposing Motion

Индивидуализация

Individualization

Диджитализация

Digitalization

Упрощение

Simplification

23 октября 2015 года

# Спасибо!

Россия, 620026, Екатеринбург  
Бажова 193, офис 501  
+7 (343) 262-35-16 (46)  
katz@katz.ru  
www.katz.ru

Россия, 191119, Санкт-Петербург  
Звенигородская 11, офис 104  
+7 (812) 309-58-98  
piter@katz.ru

Украина, 04071, Киев  
Воздвиженская 28/30, 3 эт., оф. 10  
+38 (044) 337-40-67

**Штольцман и Кац**™  
BRAND BUILDING AGENCY

